

COLOR MONITOR

KT-2914DF



SERVICE *MANUAL*

CONTENTS

1. PRECAUTIONS	2
2. PRODUCT SPECIFICATION	5
3. OPERATING INSTRUCTION	8
4. ADJUSTMENTS	10
5. TROUBLE SHOOTING GUIDE	18
6. BLOCK DIAGRAM	33
7. CONNECTING DIAGRAM	34
8. SCHEMATIC	35
9. PRINT CIRCUIT BOARD	37

1.Precautions

1-1. Safety precautions

Warnings : Service should not be attempted by anyone unfamiliar with the necessary on this Monitor.

The followings are the necessary precautions to be observed before servicing.

- 1) For continued safety, do not attempt to modify the circuit board.
- 2) Disconnect the AC power before servicing.
- 3) When the chassis is operating, semiconductor heat sinks are potential shock hazards.

1-1-1 Servicing the high voltage volume are CRT Warnings

A High Voltage volume replaced in the wrong direction may cause excessive X-Ray emissions.

- 1) Adjust in order to 26.5KV with signal at Anode.
- 2) When the troubleshooting a monitor with excessively High Voltage, avoid being unnecessarily close to the monitor. Do not operate the monitor for longer than is necessary to locate the cause of excessive voltage.
- 3) Excessive High Voltage can produce potentially hazardous X-Ray RADIATION. To avoid such hazards, the high voltage must be above the specified limit. The nominal value of the High voltage of this Monitor is 26.5KV \pm 0.3KV at zero beam current(minimum brightness) under a 120V AC power source. The High Voltage must not (under any circumstances) exceed 29KV. Each time a monitor requires servicing, the High Voltage should be checked following the High Voltage check procedure on this manual. It is recommended the reading of the voltage be recorded as a part of the service record. It is important to use an accurate and reliable High Voltage meter.
- 4) When the High Voltage regulator is operating properly, there is no possibility of an X-Ray problem.
- 5) The CRT is especially designed to prohibit X-ray emission. To ensure continued X-ray protection, replace the CRT only with one that is the same or equivalent type as the original.
- 6) Handle the CRT only when wearing shatterproof goggles and after completely.
- 7) Do not lift the CRT by the neck.

1-1-2. Fire and Shock Hazard

Before returning the monitor to the user, perform the following safety checks:

- 1) Inspect each lead dress to make certain that the leads are not pinched or that hardware is not lodged between the chassis and other metal parts in the monitor.
- 2) Inspect all protective devices such as nonmetallic control knobs, insulating materials, cabinet backs, adjustment and compartment cover or shields isolation resistor-capacitor networks, mechanical insulations, etc.
- 3) To be sure that no shock hazard exists, check for leakage current in the following manner.
 - a. Plug the AC line cord directly into a 120 or 230 Volt AC outlet.
(Do not use an isolation transformer for this test)
 - b. Using two clip leads, connect a $1.5K\Omega$, 10Watt resistor paralleled by a $0.15\mu\text{F}$ capacitor in serial with an exposed metal chassis part and a known earth ground, such as an electrical conductor and electrical ground connected to a earth ground.
 - c. Use a SSVM or VOM with 1000 ohms per-volt or sensitivity to measure the AC voltage drop across the resistor.
 - d. Connect the resistor to an exposed metal part having a return path to the chassis(metal cabinet, screw heads, knobs, shafts, escutcheon,etc) and measure the AC voltage drop across the resistor.
 - e. Any reading of 5.25 volt RMS(this corresponds to 3.5 milliampere AC) or more is excessive and indicates a potential shock hazard. Correct the shock hazard before returning the monitor to the user.

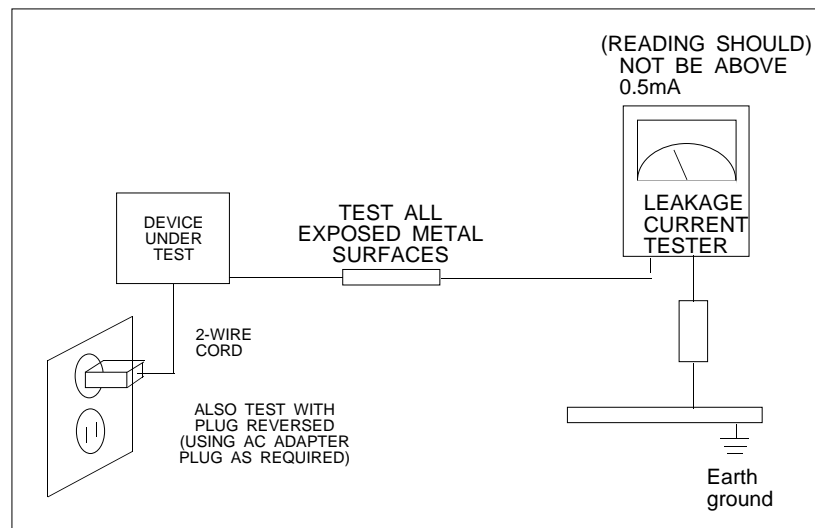

Figure 1-1. Leakage Current Test Circuit

1-1-3. Product safety notices:

Some electrical and mechanical parts have special safety related characteristics which are often not evident from visual inspection. The protection they give may not be obtained by replacing them with components rated for higher voltage, wattage, etc. Parts that have special safety characteristics are identified by \triangle on schematics and parts lists.

A substitute replacement that does not have the same safety characteristics as the recommended replacement part might create shock, fire and or other hazards. Product safety is under review continuously and new instructions whenever appropriate.

1-2. Servicing Precautions

WARNING 1 : First read the "Safety Precaution" section of this manual. if unforeseen circumstances create conflict between the servicing precautions and safety precautions, always follow the safety precautions.

WARNING 2 : A High Voltage volume replaced in the wrong direction may cause excessive X-ray emissions.

WARNING 3 : An electrolytic capacitor installed with the wrong polarity might explode.

- 1) Servicing precautions are printed on the chassis, and should be followed closely
- 2) Always unplug the units AC power cord from the AC power source before attempting to : (a) remove or reinstall any component or assembly, (b) disconnect PCB plugs or connectors, (c) connect all test components in parallel with an electrolytic capacitor.
- 3) after servicing, always check that the screws, components and wiring have been correctly reinstalled. Make sure that the area around the serviced part has not been damaged.
- 4) Check the insulation between the blades of the AC plug and accessible conductive parts (examples: metal panels, input terminals and earphone jacks).
- 5) Never defeat any of the +B voltage interlocks. Do not apply AC power to the unit (or any of its assemblies) unless all solid-state heat sinks are correctly installed.
- 6) Always connect a test instruments ground lead to the instrument chassis ground before connecting the lead; always remove the instruments lead last.

2. Product Specifications

2-1 SPECIFICATION

CDT	Tube Size Viewable Image Size Dot Pitch Deflection Angle Focusing Method	Dyna flat (option) 73 _{cm} (29") diagonal 60.5 _{cm} (24") 0.76 _{mm} (H) 110° Single Focusing (static & dynamic)
Bandwidth	Maximum	50MHz
Scanning Frequency (Auto Scanning)	Horizontal Vertical	15 ~ 40KHz 50 ~ 120Hz
Display Area	Normal Maximum	550×400 _{mm} 580×410 _{mm}
Microprocessor	User Saving Mode	6 Modes
User Control Display	OSD CONTROL	Position,Size,Pincushion,Trapezoid,H/Vcorner, Pin-B,Trapezoid,Parallel,Tilt,Moire,Zoom Color Temperature,Recall,Manual Degauss Eng/Ger/Fra/Esp/Port
Display color	Color Temperature	9300°K, 6500°K, User Color
Resolution	Maximum Mode	800 X 600 @ 60Hz
Signal Input	Connect	15 pin D-sub(Female) or Option
Safety & EMC	Safety : cUL , CE EMC : FCC , CE	
Power	Free Voltage	AC 90-264V, 60 / 50±3Hz
Power Consumption	Nomal Operation Input Current at 120V Input Current at 240V	≤100 Watts Operating : ≤ 1.5Amps rms. Turn on : ≤ 30Amps Peak. Operating : ≤ 0.8Amps rms. Turn on : ≤ 60Amps Peak.
Linearity	Cross Pattern	Horizontal : 8% Vertical : 10%
Environment	Temperature Humidity	Operating : 0 to +40℃ Storage : -40 to +60℃ Operating : 10 to 85% Storage : 5 to 95%

2-2 D-SUB SIGNAL CABLE SPECIFICATION

* VGA / SVGA

CONNECTION				REMARK
D-SUB 15PIN	IBM PC	WIRE COLOR	6P CONN 6P CONN	
1	RED	RED COAX-IN	6P CONN-4	
2	GREEN	GREEN COAX-IN	6P CONN-5	
3	BLUE	BLUE COAX-IN	6P CONN-6	
4	N.C	-	-	
5	GND	BLACK	6P CONN-3	
6	RED-GND	-	RING WIRE	
7	GREEN-GND	-		
8	BLUE-GND	-		
9	N.C	-	-	
10	ID	-	-	
11	N.C	-	-	
12	SDA	-	-	
13	H-SYNC (C/S)	ORANGE	6P CONN-1	
14	V-SYNC	WHITE	6P CONN-2	
15	SCL	-	-	
SHELL	GND	-	RING WIRE	

* CGA / EGA

CONNECTION				REMARK
CGA SLOT	ZAMMA Spec_	WIRE COLOR	6P CONN 6P CONN	
1 , A	H-SYNC	WHITE	6P CONN-1	
16	V-SYNC	YELLOW	6P CONN-2	
28 , f	GND & SHELL	BLACK	6P CONN-3	
T	BLUE	BLUE	6P CONN-4	
17	GREEN	GREEN	6P CONN-5	
U	RED	RED	6P CONN-6	

2-3 TIMING CHART

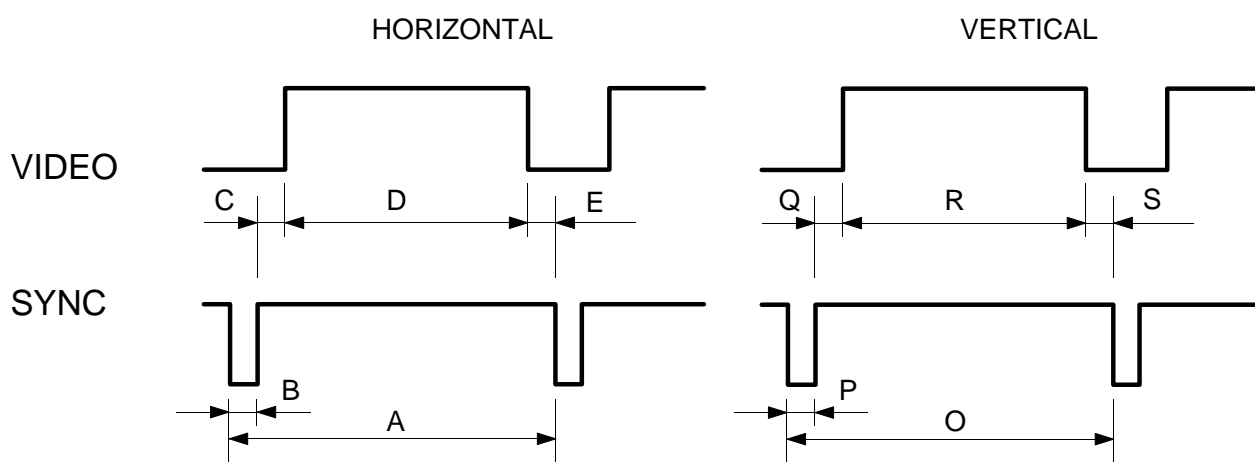

A : LINE TIME TOTAL
C : BACK PORCH
E : FRONT PORCH

B : HORIZONTAL SYNC WIDTH
D : ACTIVE TIME

O : FRAME TIME TOTAL
Q : BACK PORCH
S : FRONT PORCH

P : VERTICAL SYNC WIDTH
R : ACTIVE TIME

DESCRIPTION		CGA		EGA	VGA	SVGA
		640 x 200	640 x 200	640 x 400	640*480	800*600
H	f KHz	15.750	15.750	24.827	31.469	37.88
	A uS	63.5	63.5	40.28	31.778	26.40
	B uS	8.671	8.672	3.04	3.813	3.20
	C uS	7.272	7.272	3.8	1.907	2.20
	D uS	40.836	40.836	30.399	25.422	20.00
	E uS	6.72	6.72	3.04	0.636	1.00
	POL.	POS	POS	POS	NEG	POS
V	f Hz	50	60.115	55.609	59.940	60.317
	O mS	20.0	16.63	17.98	16.683	16.58
	P mS	0.444	0.444	0.322	0.064	0.11
	Q mS	0.825	0.825	1.26	1.048	0.61
	R mS	18.603	15.302	16.111	15.253	15.84
	S mS	0.128	0.06	0.282	0.318	0.03
	POL.	POS	POS	POS	NEG	POS

3. Operating Instruction

3-1 FRONT FRAME



3.2 MAIN PCB ASS'Y

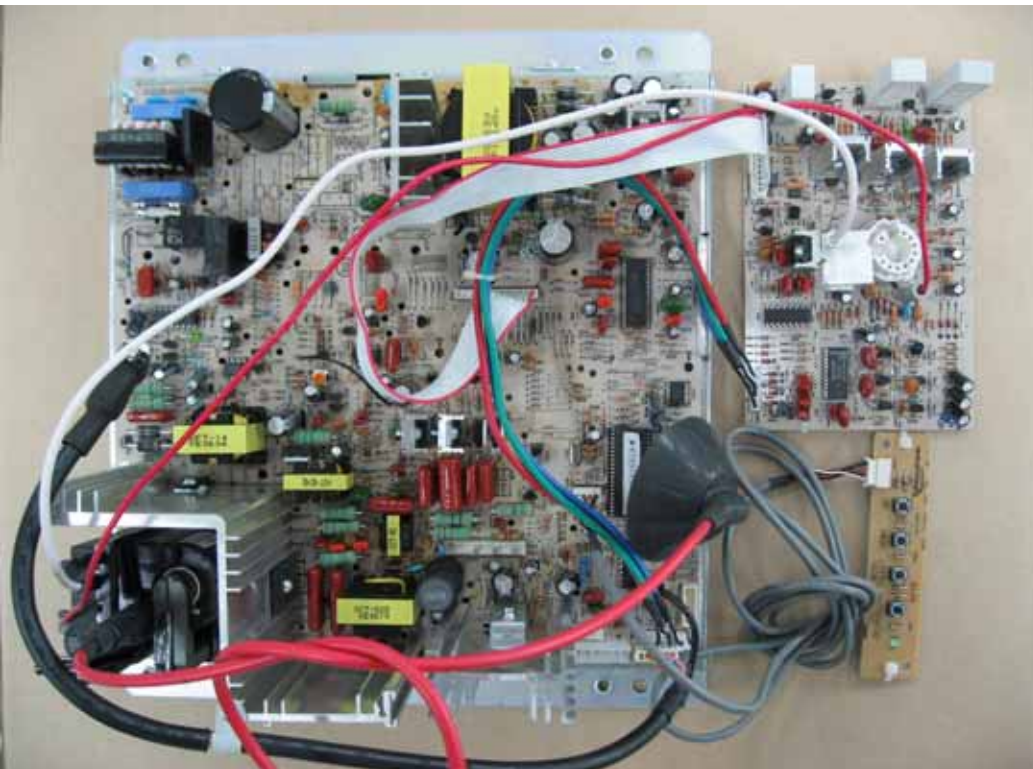

3-3. Function of Control

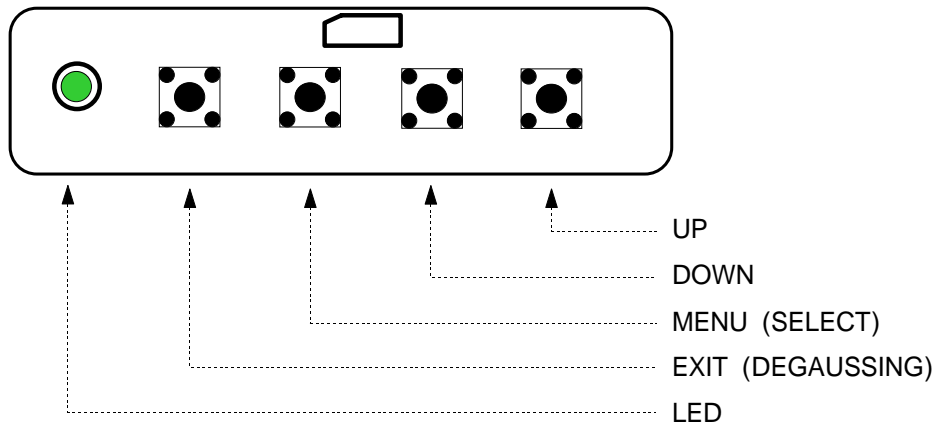

Control	Function
LED (Power Indicator)	The light of power LED changes according to each state. ◎ on mode : Green LED. ◎ power saving mode : green LED blinking.
MENU(Select)	When you press this button, the MENU appears. The MENU will disappear in 10 seconds if you don't operate any button. When you press EXIT button again, the MENU disappears. This button is used to select the control item on the MENU. In MENU, the control item could be selected and unselected by this button.
EXIT	This button is used to exit the value of any selected control.
UP	This button is used to increase the value of any selected control. This button is used to locate to the next control item for select.
DOWN	This button is used to decrease the value of any selected control. This button is used to locate to the previous control item for select.

4.Adjustments

4-1. Adjustment Control

4-1-1. Before making Adjustments

1) Orientation

When servicing, always face the monitor to east.

2) Warm-up time

The monitor must be on for 30 minutes before starting alignment. Warm-up time is especially critical in color temperature and white balance adjustments.

3) Signal

Analog, 0.714Vp-p positive at 75Ω, internal termination.

4) High Voltage Adjustment

Signal : without signal

Adjustment : 26.5KV ± 0.5KV.

PROCEDURE

① Disconnect the AC line cord from the power source.

② Connect positive end of High Voltage probe to anode cap of CRT, negative end of to GND(main chassis)

③ First of all Disconnect AC cord and than disconnect High voltage probe.

5) Screen Voltage

- signal : 640 * 480 (60Hz) , Full white
- Bright : max
- Contrast : max
- Adjustment (SAMSUNG SDI) : 600±20V

4-1-2 TURN ON THE FACTORY OSD MANUAL METHOD

- 1) press on the "UP" key.
- 2) connect the AC line cord from the power source.
- 3) At this time OSD menu changed factory mode.



4-2. Display Control Adjustment

Click on the "MENU" button (OSD MENU).

This menu is user's OSD manual.(user's manual)

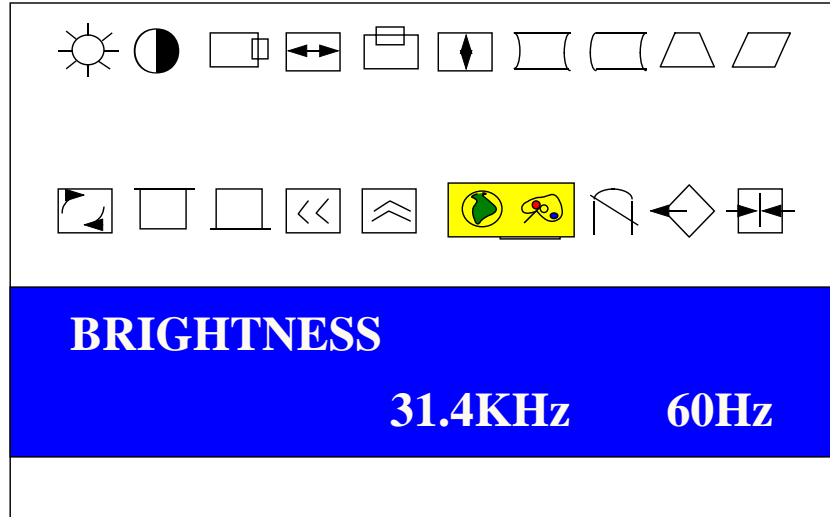

- 1) Click on the "MENU" button.
- 2) Click on the "UP" or "DOWN" and move any function control.
- 3) Press the "MENU(SELECT)" button.
- 4) "UP" or "DOWN" button is used to control the value of any function.
- 5) When you press exit button, the MENU disappears.

4-2-1 Screen center adjustment

width : 520mm height : 400mm

signal : 640 * 480 (60Hz)

| A-B | ≤ 4.0mm , | C-D | ≤ 4.0mm

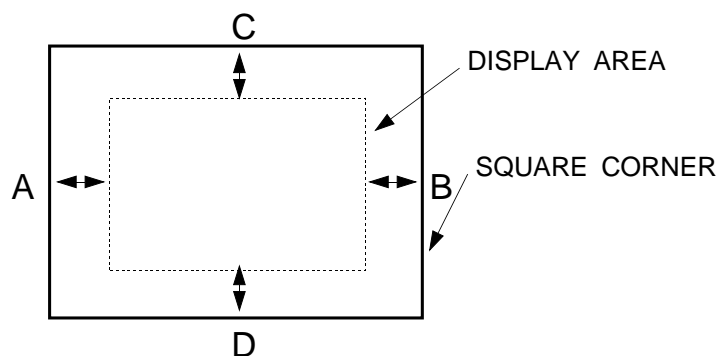

a) Horizontal size adjustment

adjustment : use to "H-SIZE", $520 \pm 3\text{mm}$

b) Vertical size adjustment

adjustment : use to "V-SIZE", $400 \pm 3\text{mm}$

c) Horizontal position adjustment

adjustment : use to "H-POS"

d) Vertical position adjustment

4-2-2 Trapezoid adjustment

frequency : all mode

signal pattern : cross hatch

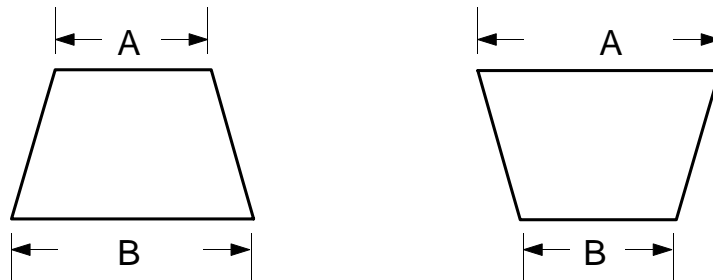

$$|A - B| < 2.5\text{mm}$$

4-2-3 Pin balance adjustment

frequency : all mode

signal pattern : cross hatch

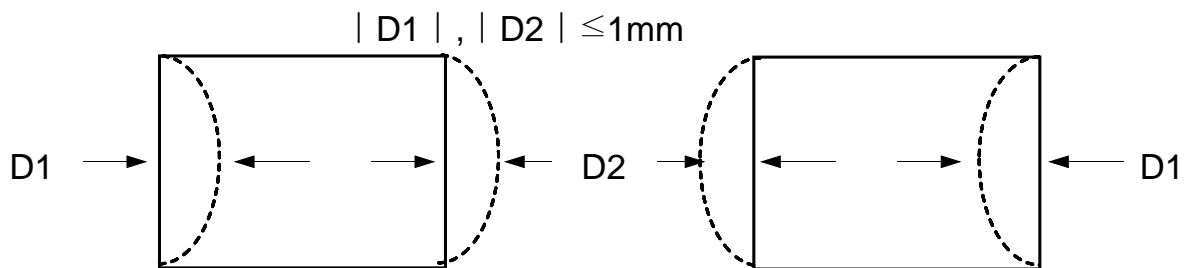

4-2-4 Parallelogram adjustment

frequency : all mode

signal pattern : cross hatch

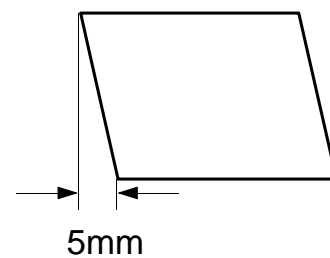

4-2-5 Side pin-cushion adjustment

frequency : all mode

signal pattern : cross hatch

brightness : MIN (cut-off)

contrast : MAX

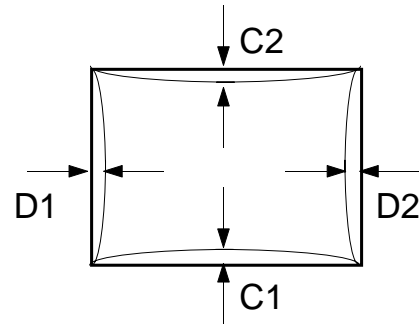

$$| C1 | , | C2 | \leq 2.0\text{mm}, | D1 | , | D2 | \leq 2.0\text{mm}$$

4-2-6 Tilt adjustment

frequency : all mode

signal pattern : cross hatch

brightness : MIN (cut-off)

contrast : MAX

4-2-7 Degaussing adjustment

Don't adjust the degaussing. Degaussing is possible in OSD adjustment menu. After using this function once, You must use again after at least 30minutes.

4-2-8 SAVE ADJUSTMENT CONDITION & REMOVE USER MODE.

4-3 Color adjustment

4-3-1 color temperature

※ Set condition

- measuring instrument : color analyzer (CA-100)
- frequency : 640 * 480 (60Hz)
- display pattern : full white , one square(25% window)
- brightness : cut off
- contrast : MAX

※ specification

- 9300K $x=0.281\pm0.02$, $y=0.311\pm0.02$
- 6500K $x=0.313\pm0.02$, $y=0.329\pm0.02$

4-3-2 color adjustment (9300K)

a) Back raster color adjustment

※ Set condition

- frequency : 640 * 480 (60Hz)
- display pattern : back raster pattern
- brightness : MIN (cut off)
- contrast : MAX

1. Select factory mode.
2. Select COLOR TEMP with UP.DOWN key.
3. Select 9300K.
4. Adjust back raster brightness to 0.01~0.02(F/L) with VR601.
5. Select B-B with UP,DOWN adjust $y=0.311$ and do the next selection with EXIT key.
6. Select R-B with UP,DOWN adjust $x=0.281$ and do the next selection with EXIT key.

a) white balance / ACL adjustment

※ Set condition

- frequency : 640 * 480 (60Hz)
- display pattern : one square(25% window) , full white
- brightness : MIN (cut off)
- contrast : MAX

1. Select factory mode.
2. Select COLOR TEMP with UP,DOWN key.
3. Select 9300K.
4. Select B-G with UP,DOWN adjust $y=0.311$ and do the next selection with EXIT key.
6. Select R-G with UP,DOWN adjust $x=0.281$ and do the next selection with EXIT key.
7. Select contrast icon with UP,DOWN key, adjust contrast to 50~60f/l with UP,DOWN key.

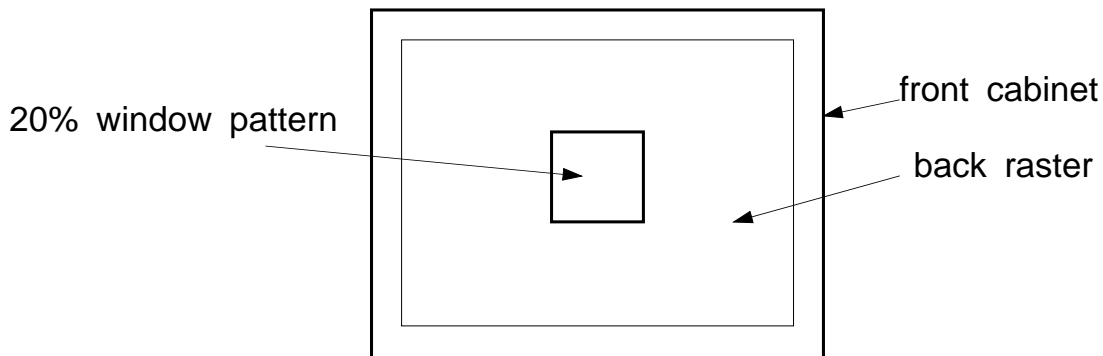

8. Select ACL key(A/C) in full white pattern and adjust ACL to 28~30f/l.

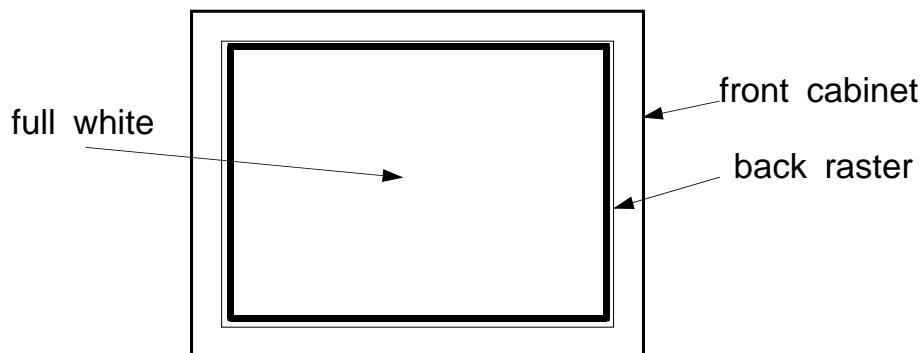

※ attention : If 50f/l doesn't adjust in 20% window, adjust G-G again with DOWN key.

4-3-3 color adjustment (6500K)

a) white balance adjustment

1. Select factory mode.
2. Select COLOR TEMP with UP,DOWN key.
3. Select 6500K.

4. Select B-G with UP,DOWN adjust $y=0.329$ and do the next selection with EXIT key.
6. Select R-G with UP,DOWN adjust $x=0.313$ and do the next selection with EXIT key.

4-3-4 brightness uniformity adjustment

※ set condition

- frequency : 640 * 480 (60Hz)
- display pattern : 9 ball pattern
- brightness : MIN (cut off)
- contrast : MAX

Measure nine brightness display in the screen.

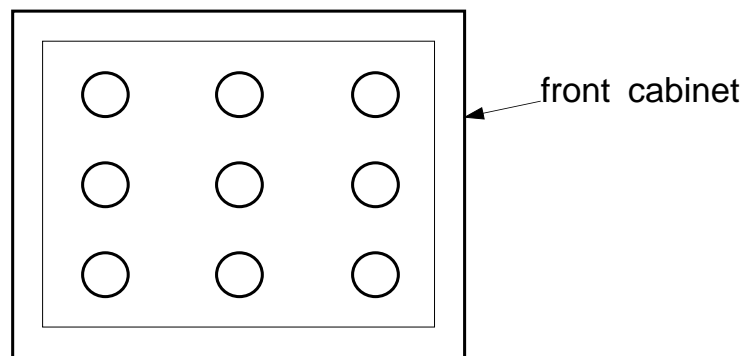

4-3-5 Focus adjustment

※ set condition

- frequency : 640 * 480 (60Hz)
- display pattern : "H" character
- brightness : min (cut off)
- contrast : max

1. Adjust in focus of whole screen to be the best fitted with FOCUS V/R in FBT.

4-3-6 PURITY adjustment

Purity is that unnecessary colors appear in the screen except displayed color. Don't appear unnecessary colors divided with the naked eye at a distance of 50cm from CRT surface.

※ set condition

- direction : east
- frequency : included timing chart
- display pattern : full white
- brightness : MIN (cut off) - display center

Most suitable		
RED	$x=0.640 \pm 0.015$	$y=0.323 \pm 0.015$
GREEN	$x=0.295 \pm 0.015$	$y=0.594 \pm 0.015$
BLUE	$x=0.142 \pm 0.015$	$y=0.066 \pm 0.015$

5. TROUBLESHOOTING GUIDE

5-1. Troubleshooting Guide.

NOTES ;

1. If picture does not appear, fully rotate the brightness and contrast controls clockwise.
2. Check the following circuits.
 - No raster appear : power circuit. Horizontal output circuit.
 - High voltage control circuit and output circuit.
 - High voltage develops but no raster appears : Video output circuit.
 - High voltage does not develop : Horizontal output circuit.

5-2-1. No Raster, No Video

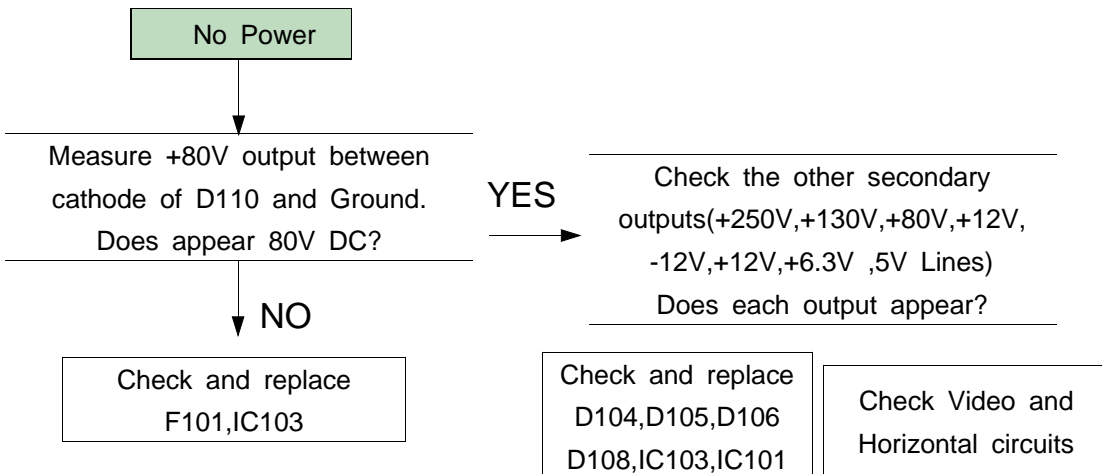

5-2-2 S-Correction failure.

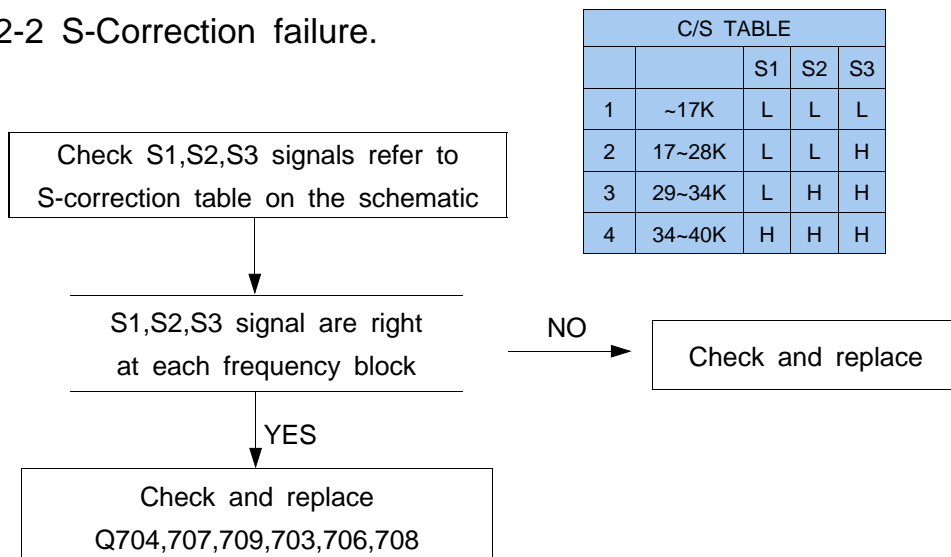

C/S TABLE				
		S1	S2	S3
1	~17K	L	L	L
2	17~28K	L	L	H
3	29~34K	L	H	H
4	34~40K	H	H	H

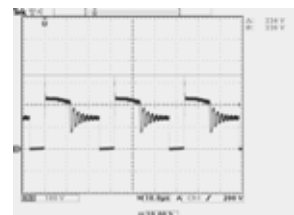

IC103 1pin

5-2-3 Degaussing failure

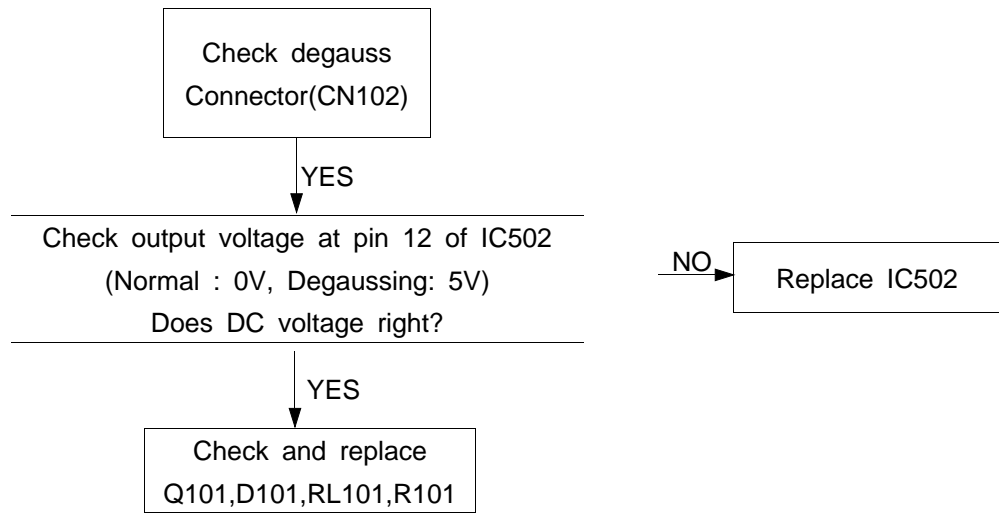

5-2-3 Purity failure

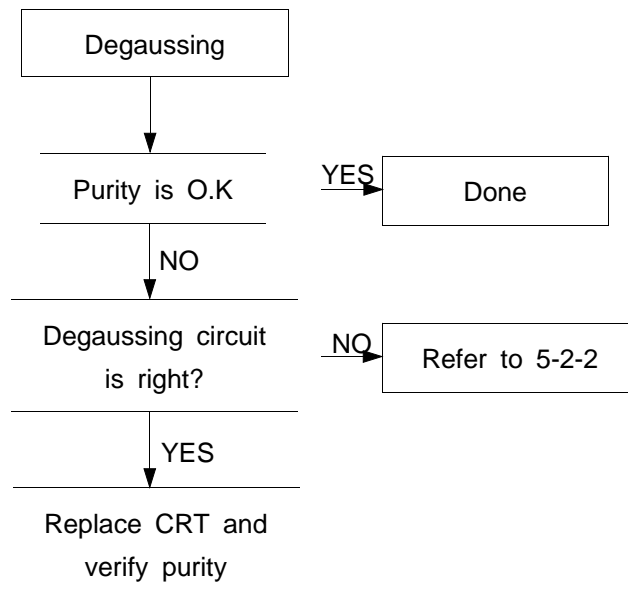

5-2-4 Rotation Failure

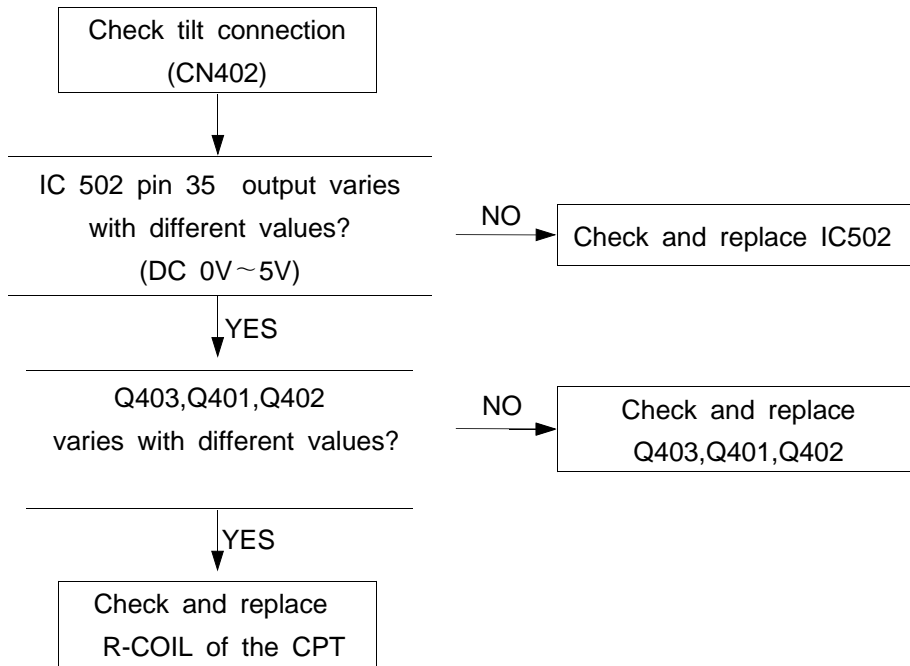

5-2-5 Misconvergence Failure

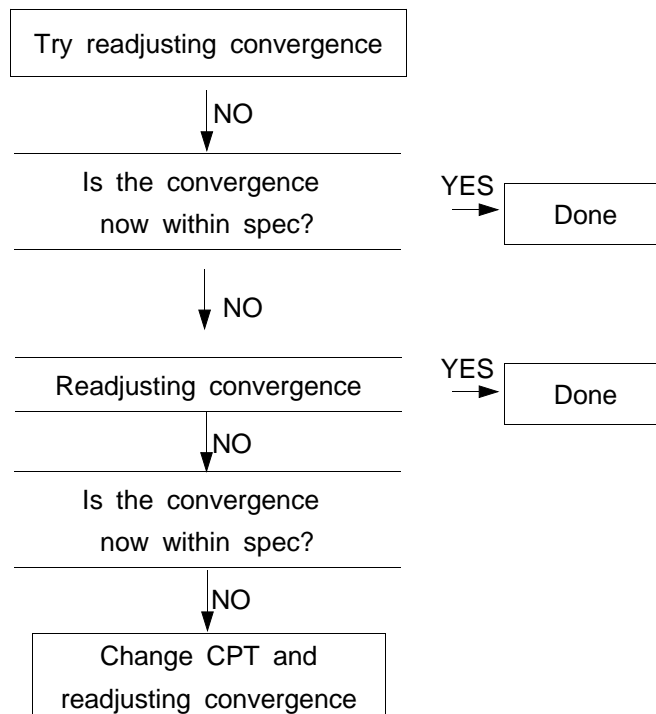

5-2-6 H-Linearity Failure

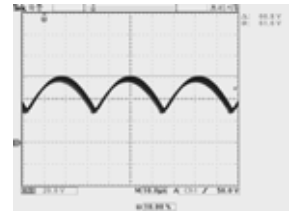
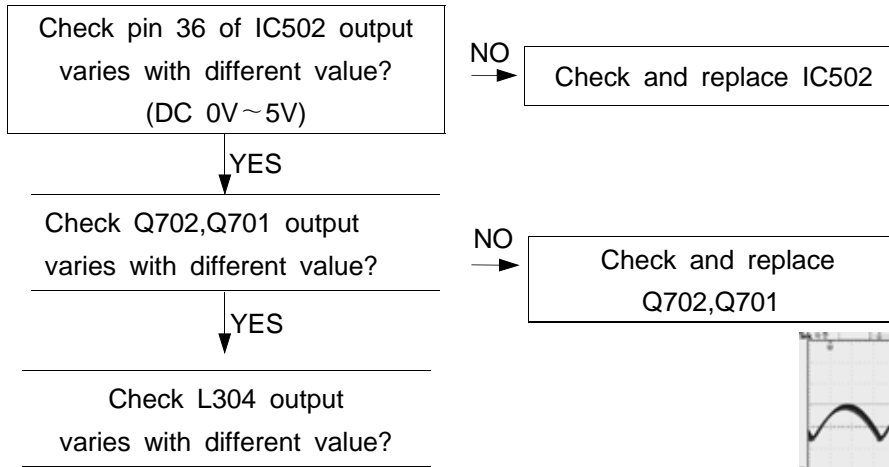

L304

5-2-7 High Voltage Failure

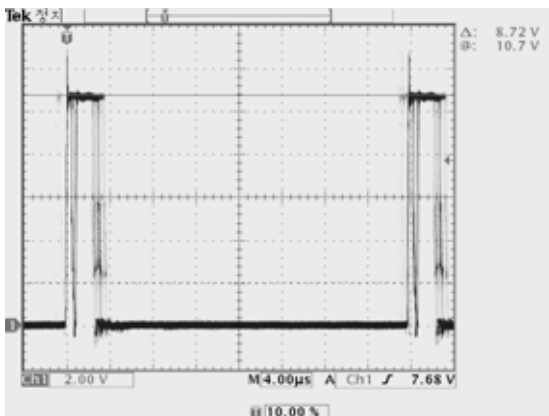
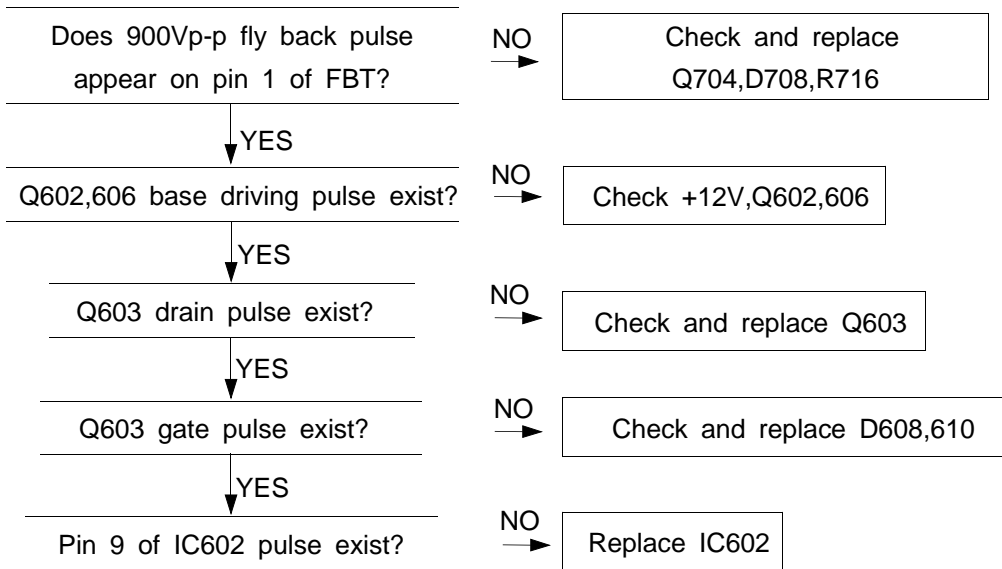

Q602,Q606 BASE

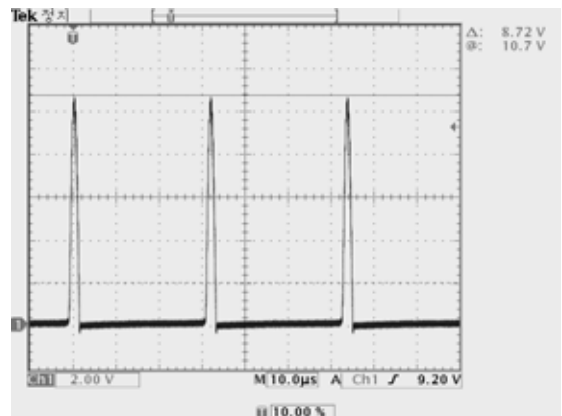

FBT 1pin

5-2-8 User control Failure

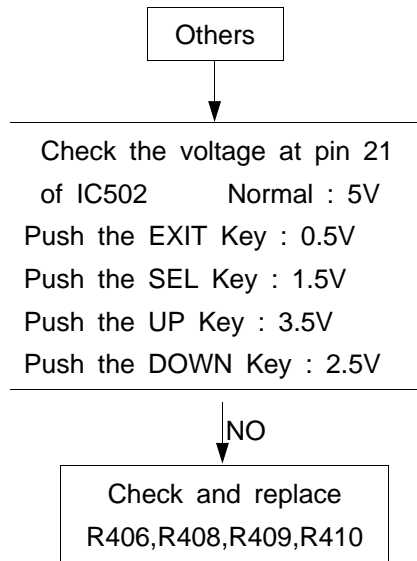

5-2-10 Dynamic Focus Failure or poor Focus

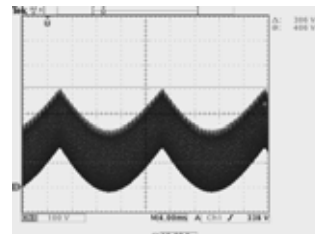
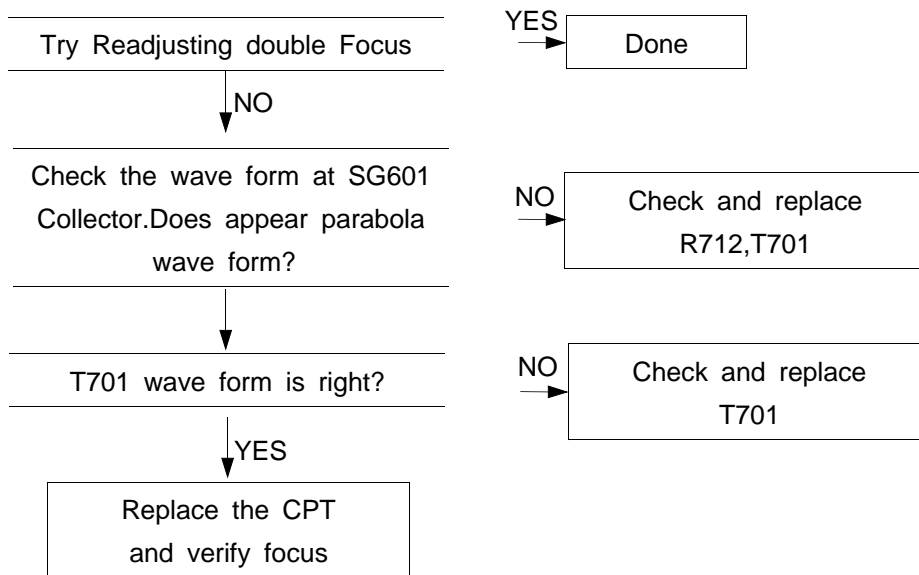

T701

5-2-10 Visible Retrace

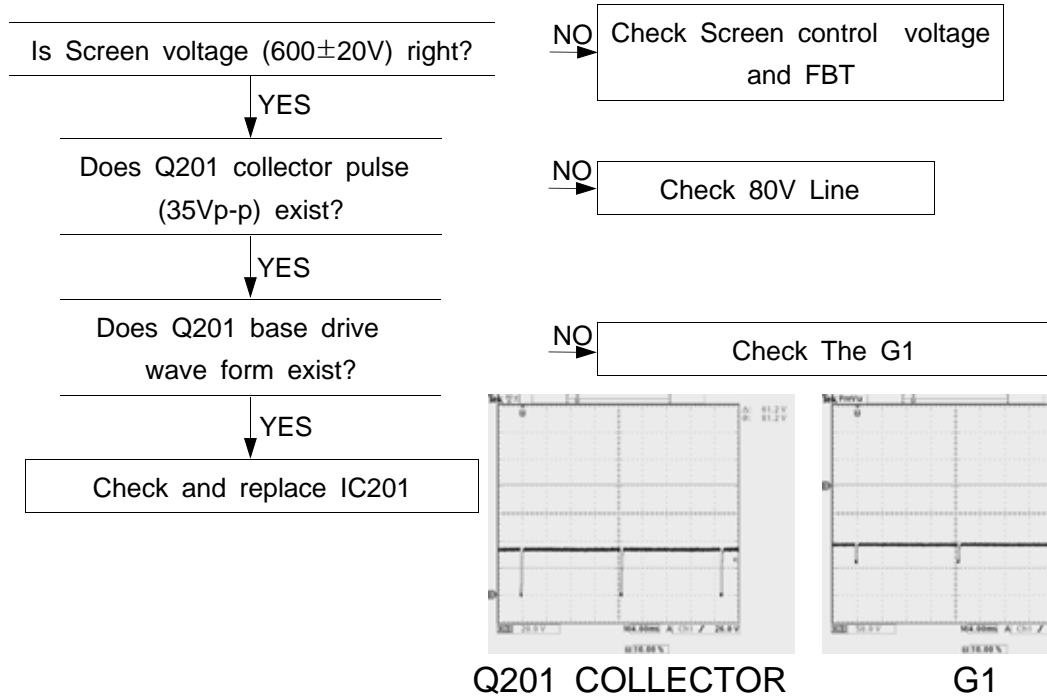

5-2-11 ACL Failure

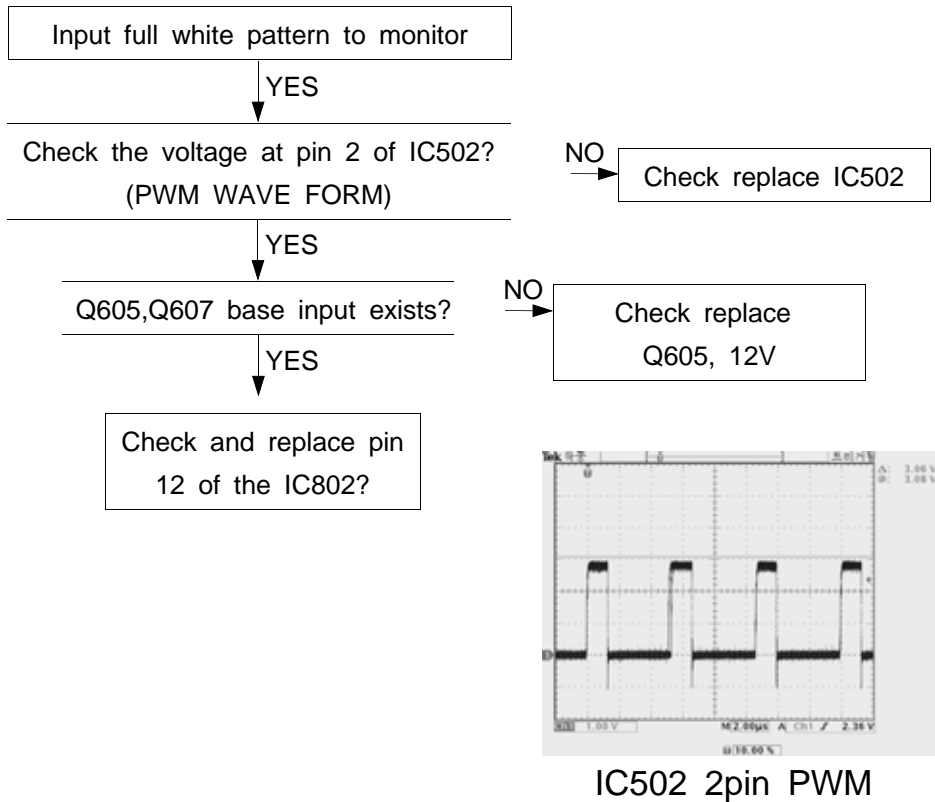

5-2-12 Micom Failure

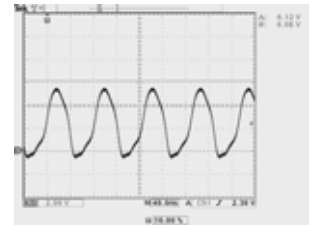
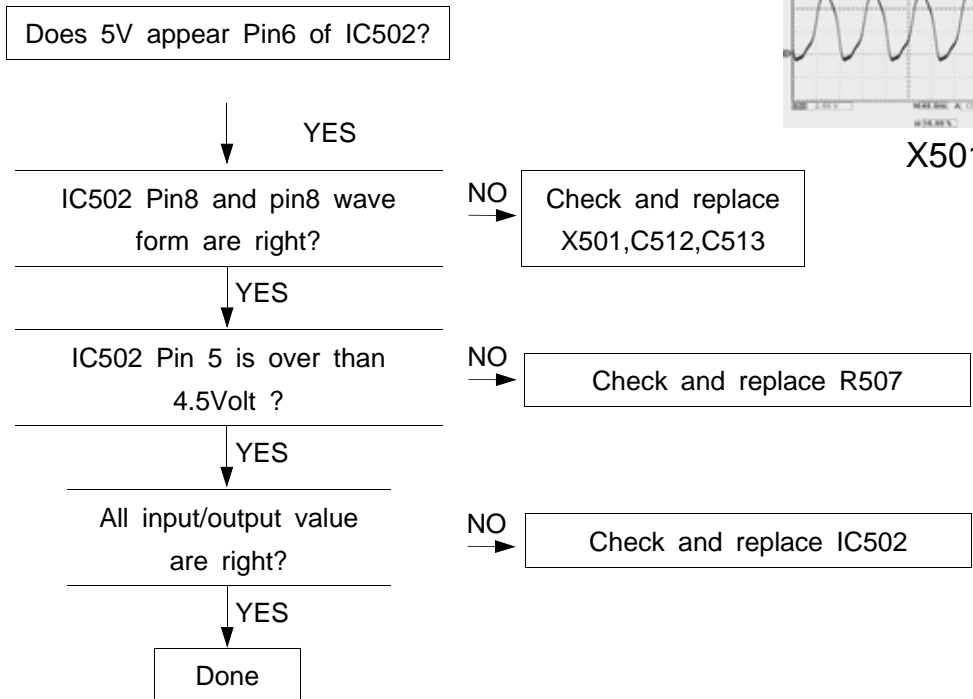

X501

5-2-13 No Raster

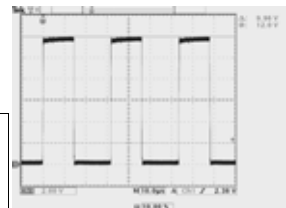
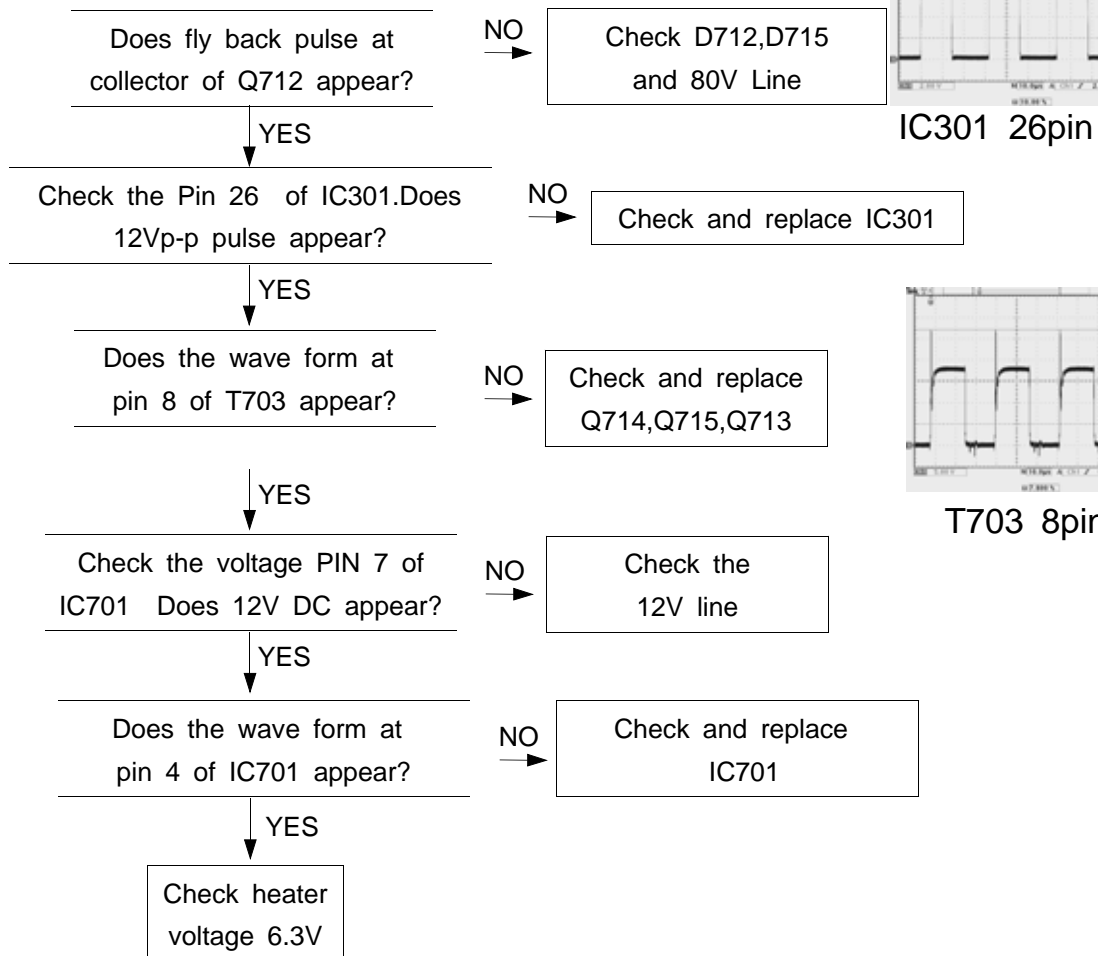

IC301 26pin

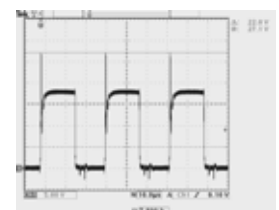

T703 8pin

5-2-14 No Video

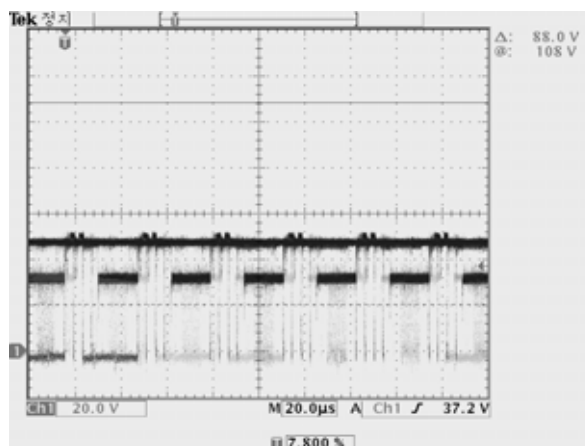
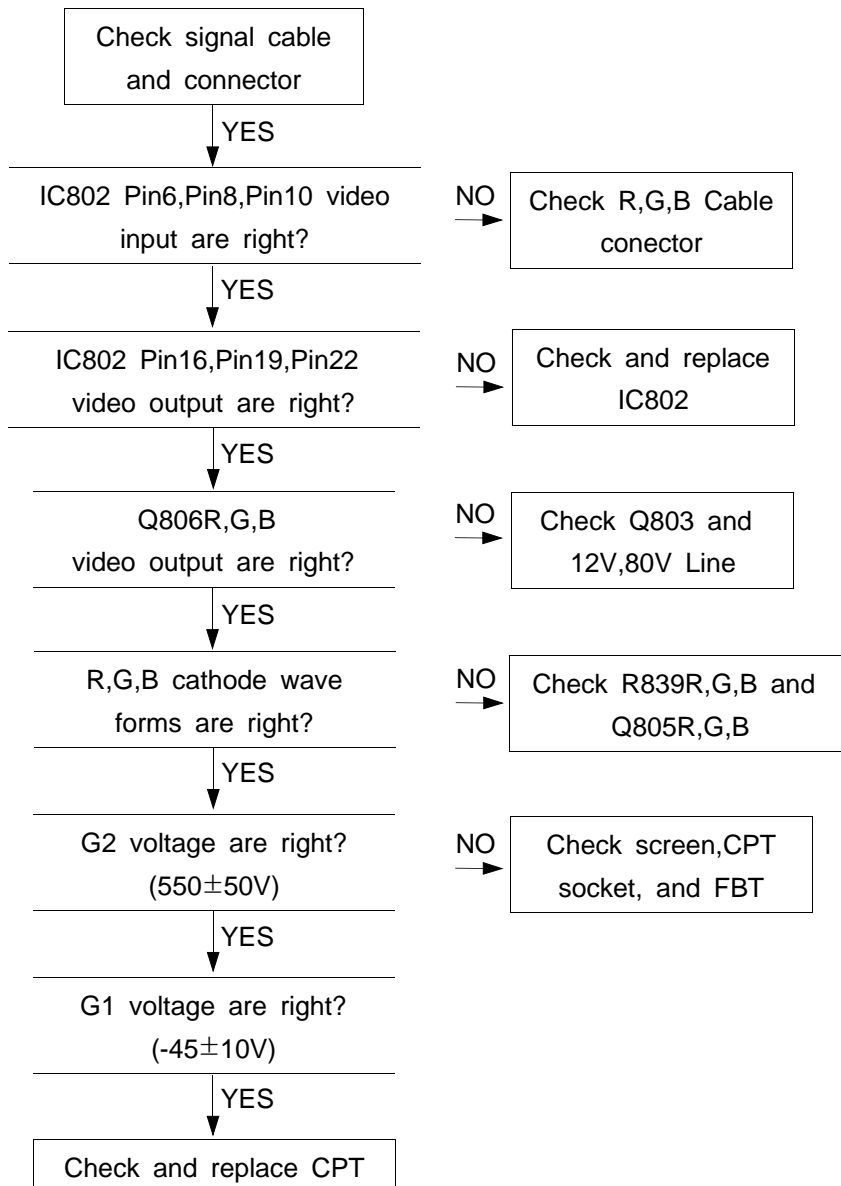

R,G,B Cathode wave form

5-2-15 Abnormal & Invariable H-size

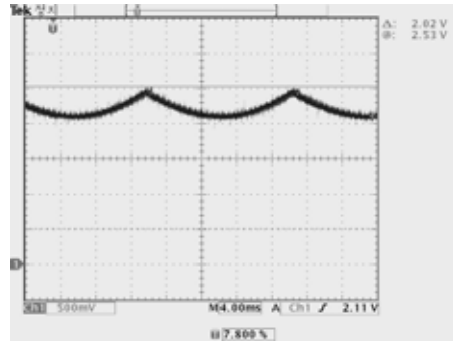
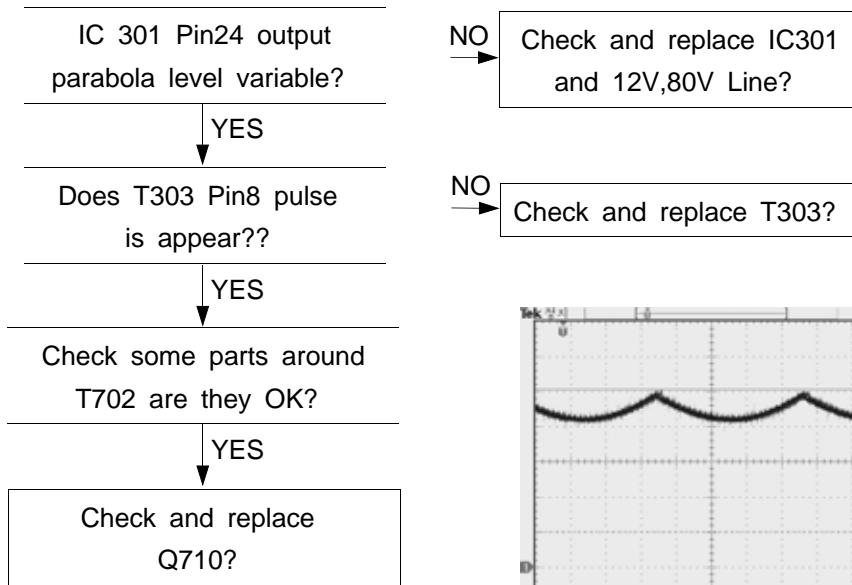

IC301 24pin

5-2-16 OSD failure

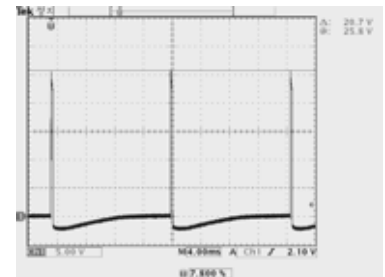
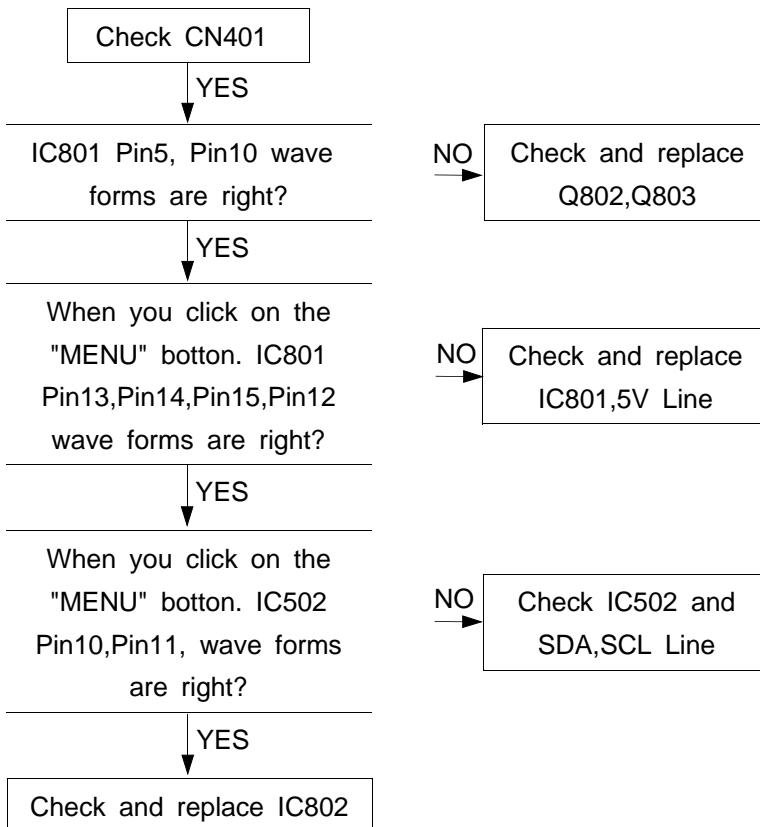

V-FLY

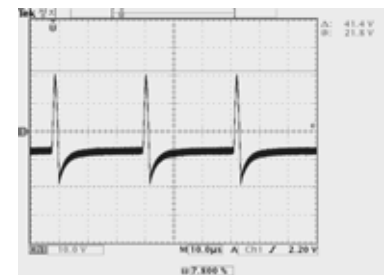

H-FLY

5-2-17 V-deflection failure

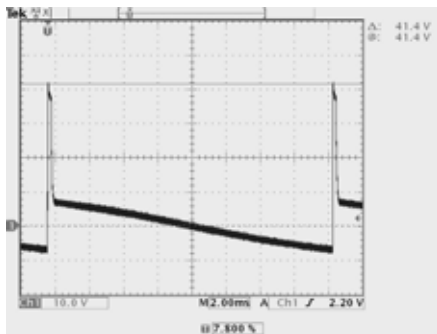
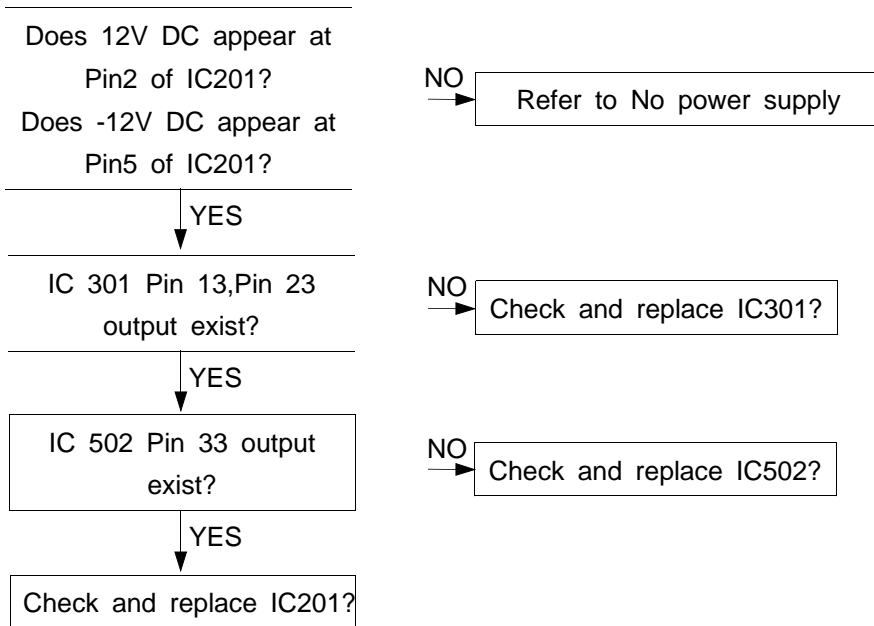

IC201 5 pin

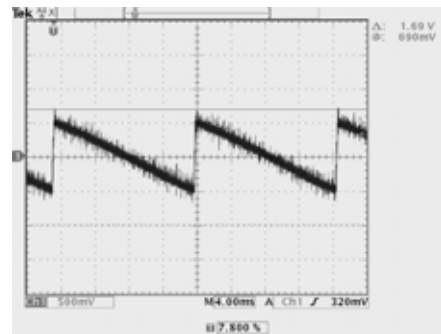

IC201 1 pin

7. BLOCK DIAGRAM

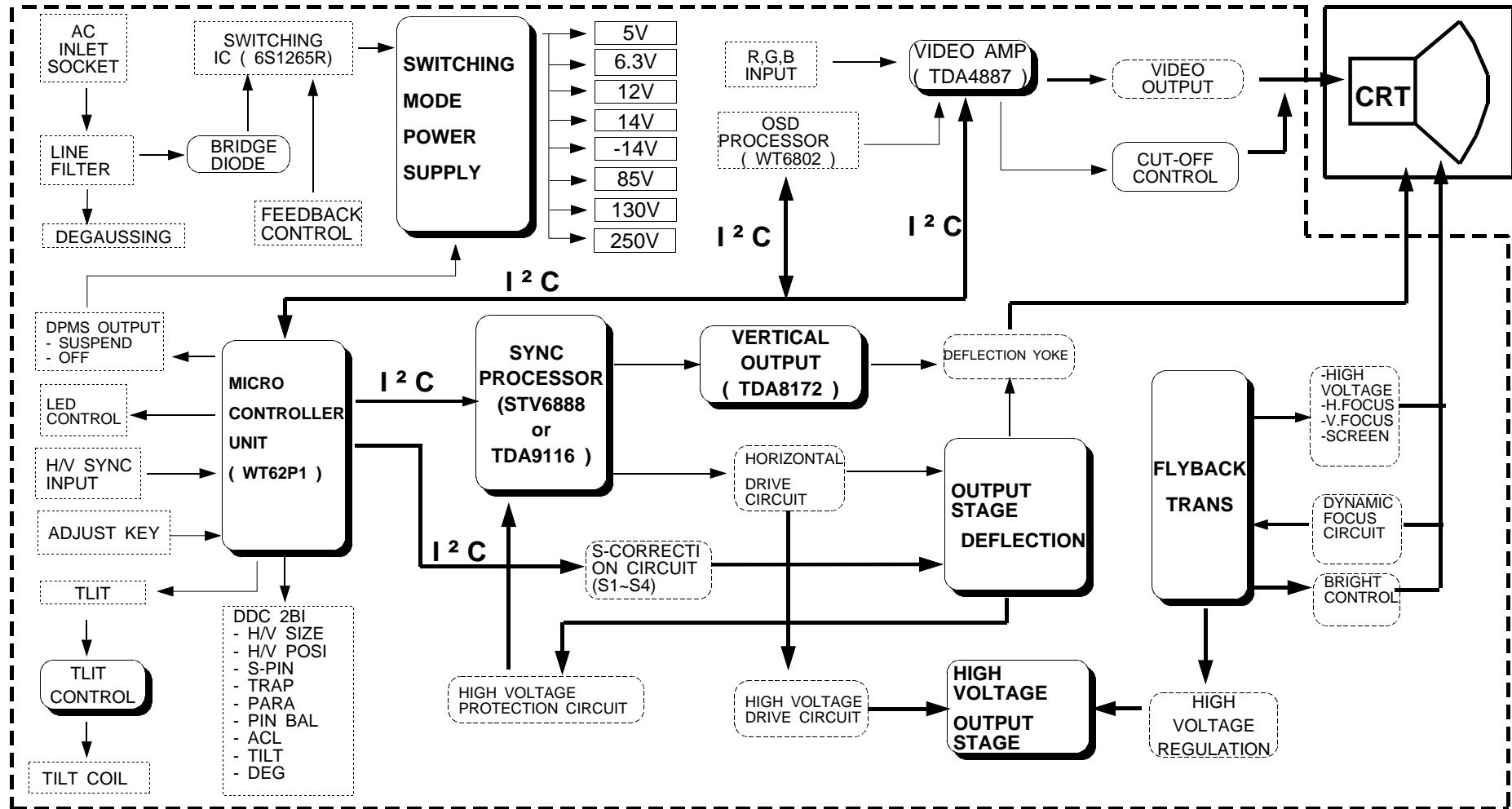

7. CONNECTING DIAGRAM

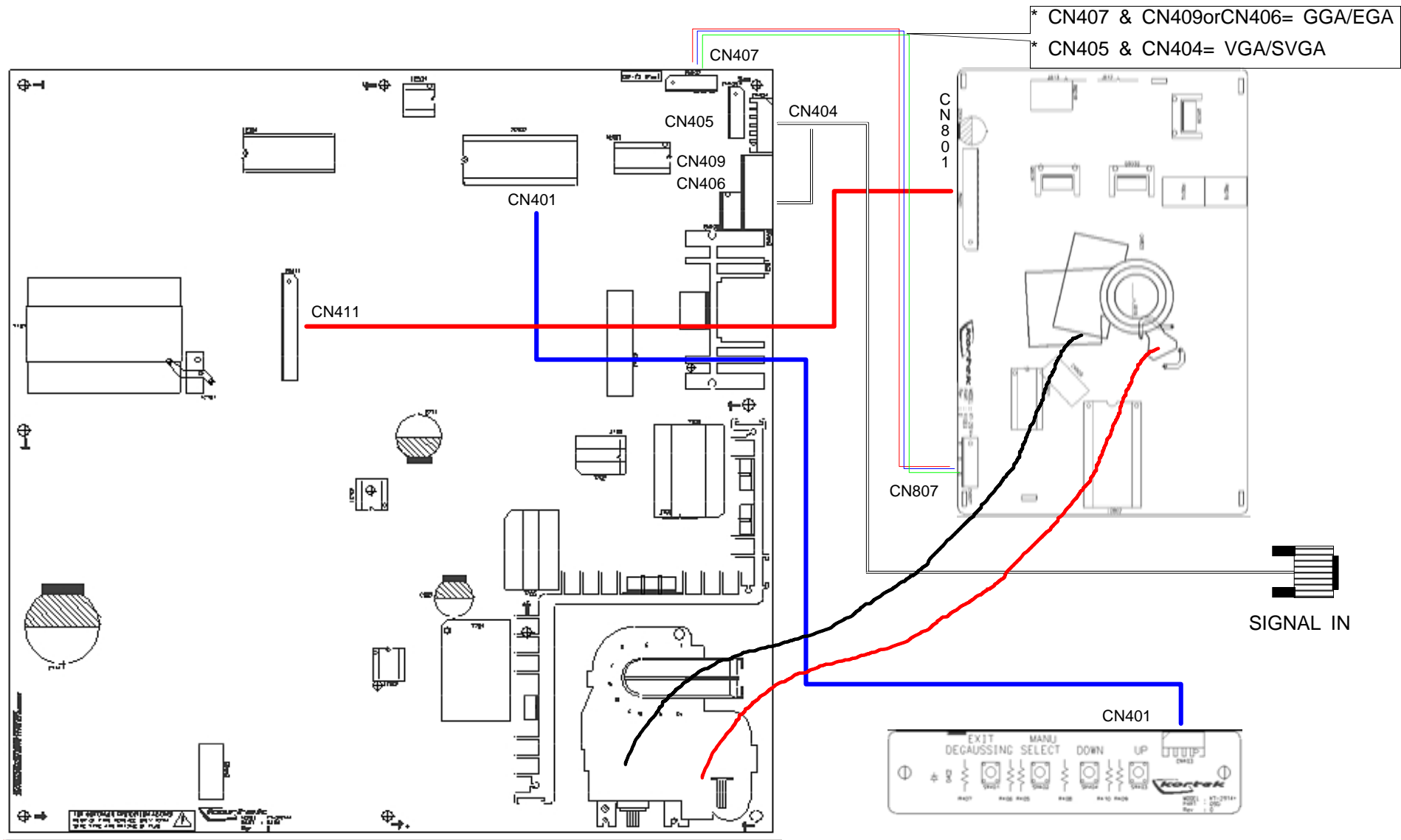

8. SCHEMATIC

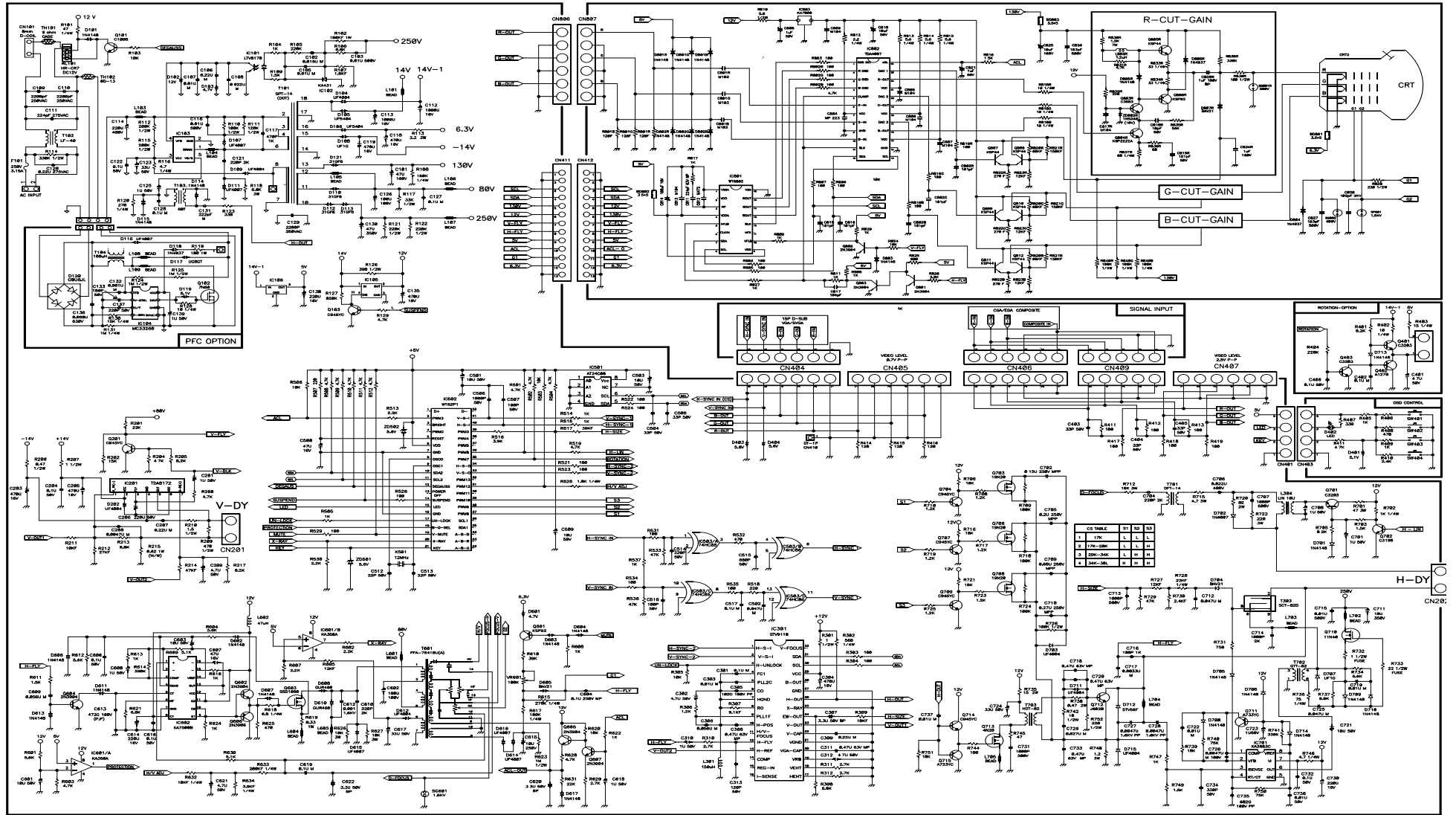

9. PRINT CIRCUIT BOARD

10-1 MAIN

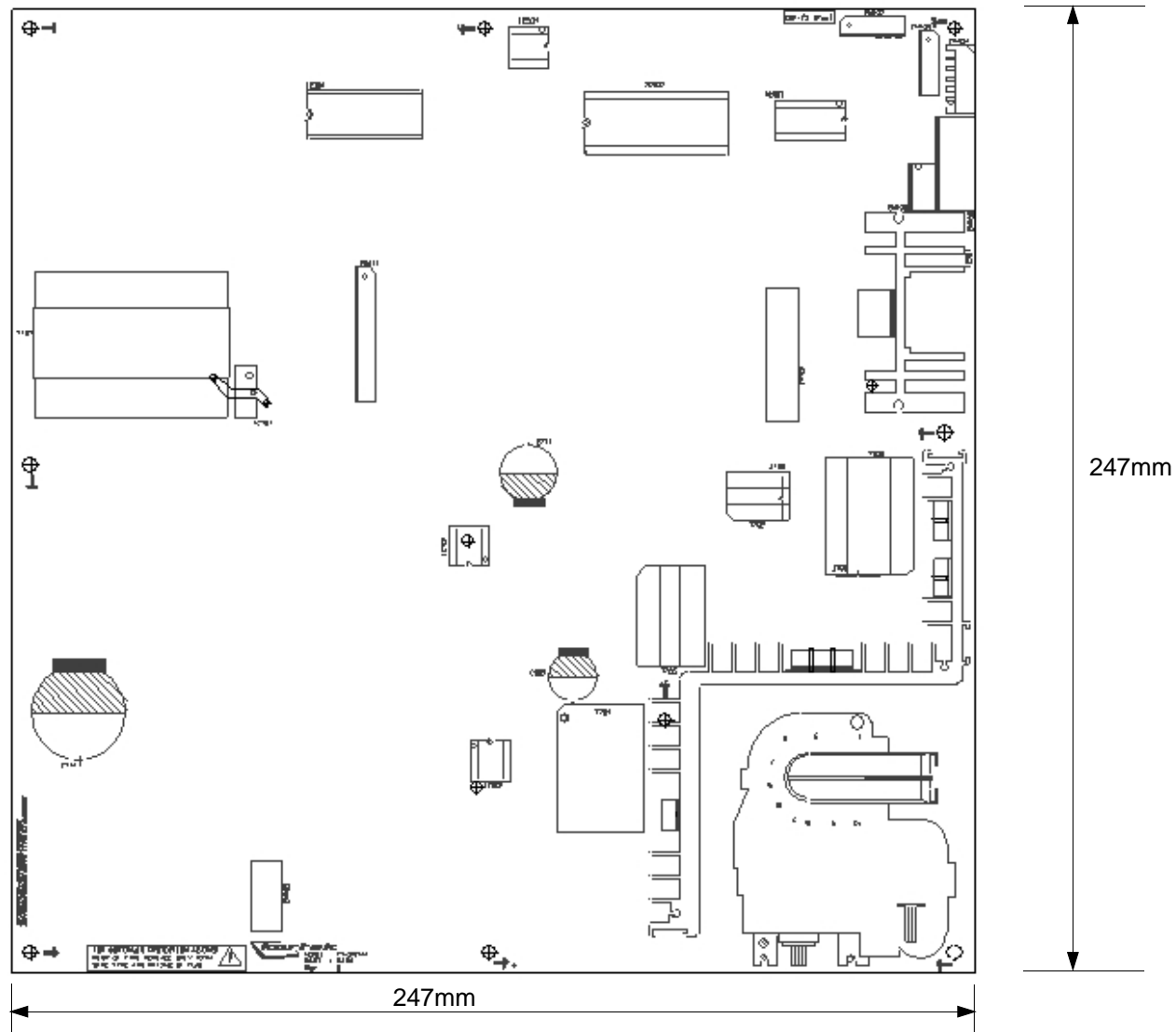

9. PRINT CIRCUIT BOARD

10-2 VIDEO

